

Installation Note

8757D/E CRT to LCD Upgrade Kit
Part Number 08757-60159



Agilent Technologies

Agilent Part Number: 08757-90195

Printed in USA June 2003

© Copyright 2003 Agilent Technologies, Inc. All rights reserved.



08757-90195

Notice

THE MATERIAL CONTAINED IN THIS DOCUMENT IS PROVIDED “AS IS,” AND IS SUBJECT TO BEING CHANGED, WITHOUT NOTICE, IN FUTURE EDITIONS. FURTHER, TO THE MAXIMUM EXTENT PERMITTED BY APPLICABLE LAW, AGILENT DISCLAIMS ALL WARRANTIES, EITHER EXPRESS OR IMPLIED WITH REGARD TO THIS MANUAL AND ANY INFORMATION CONTAINED HEREIN, INCLUDING BUT NOT LIMITED TO THE IMPLIED WARRANTIES OF MERCHANTABILITY AND FITNESS FOR A PARTICULAR PURPOSE. AGILENT SHALL NOT BE LIABLE FOR ERRORS OR FOR INCIDENTAL OR CONSEQUENTIAL DAMAGES IN CONNECTION WITH THE FURNISHING, USE, OR PERFORMANCE OF THIS DOCUMENT OR ANY INFORMATION CONTAINED HEREIN. SHOULD AGILENT AND THE USER HAVE A SEPARATE WRITTEN AGREEMENT WITH WARRANTY TERMS COVERING THE MATERIAL IN THIS DOCUMENT THAT CONFLICT WITH THESE TERMS, THE WARRANTY TERMS IN THE SEPARATE AGREEMENT WILL CONTROL.

Getting Assistance from Agilent

By internet, phone, or fax, get assistance with all your test and measurement needs.

| | | |
|--|---|--|
| Online assistance: www.agilent.com/find/assist | | |
| United States <i>(tel)</i> 1 800 452 4844 | Latin America <i>(tel)</i> (305) 269 7500 <i>(fax)</i> (305) 269 7599 | Canada <i>(tel)</i> 1 877 894 4414 <i>(fax)</i> (905) 282-6495 |
| Europe <i>(tel)</i> (+31) 20 547 2323 <i>(fax)</i> (+31) 20 547 2390 | Australia <i>(tel)</i> 1 800 629 485 <i>(fax)</i> (+61) 3 9210 5947 | New Zealand <i>(tel)</i> 0 800 738 378 <i>(fax)</i> (+64) 4 495 8950 |
| Japan <i>(tel)</i> (+81) 426 56 7832 <i>(fax)</i> (+81) 426 56 7840 | Singapore <i>(tel)</i> 1 800 375 8100 <i>(fax)</i> (65) 836 0252 | Malaysia <i>(tel)</i> 1 800 828 848 <i>(fax)</i> 1 800 801 664 |
| India <i>(tel)</i> 1 600 11 2929 <i>(fax)</i> 000 800 650 1101 | Hong Kong <i>(tel)</i> 800 930 871 <i>(fax)</i> (852) 2506 9233 | Taiwan <i>(tel)</i> 0800 047 866 <i>(fax)</i> (886) 2 25456723 |
| Philippines <i>(tel)</i> (632) 8426802 <i>(tel)</i> (PLDT subscriber only) 1 800 16510170 <i>(fax)</i> (632) 8426809 <i>(fax)</i> (PLDT subscriber only) 1 800 16510288 | Thailand <i>(tel)</i> (outside Bangkok) (088) 226 008 <i>(tel)</i> (within Bangkok) (662) 661 3999 <i>(fax)</i> (66) 1 661 3714 | People’s Republic of China <i>(tel)</i> (preferred) 800 810 0189 <i>(tel)</i> (alternate) 10800 650 0021 <i>(fax)</i> 10800 650 0121 |

Description of CRT to LCD Upgrade Kit

This upgrade kit replaces the cathode ray tube (CRT) with a liquid crystal display (LCD).

About the Upgrade Kit

| | |
|--|--|
| Products affected: | 8757D and all options 8757E and all options |
| Installation to be performed by: | Agilent service center, personnel qualified by Agilent, or customer |
| Estimated installation time: | 3 hours |
| Estimated verification time: | 20 minutes |

If you need assistance, contact Agilent Technologies. Refer to [“Getting Assistance from Agilent” on page 2](#) for a list of offices.

Items Included in the Upgrade Kit

Table 1 lists the parts included in this upgrade kit, Agilent part number 08757-60159. Check the contents of your kit against this list.

NOTE As you step through the removal portion of this procedure, discard all of the old hardware. New hardware is provided in the upgrade kit.

Table 1 Upgrade Kit Contents (08757-60159)

| Description | Qty | Part Number |
|--|-----|-------------|
| Manual set (includes service and operating manual) | 1 | 08757-90107 |
| Installation note (this document) | 1 | 08757-90195 |
| Front sub-panel (sheet metal) | 1 | 08757-00071 |
| LCD shield | 1 | 08757-00072 |
| Switch guide | 1 | 08757-40008 |
| Main keypad rubber | 1 | 08757-40017 |
| Power supply cable | 1 | 08757-60071 |
| Display interface board | 1 | 85101-60293 |
| Keypad board | 1 | 08757-60149 |
| LCD assembly | 1 | 08757-60151 |
| Rear panel assembly | 1 | 08757-60153 |
| Front panel overlay Option 012 | 1 | 08757-80083 |
| Front panel overlay 8757D Standard | 1 | 08757-80084 |
| Front panel overlay Option 001 | 1 | 08757-80085 |
| Front panel overlay Option 002 | 1 | 08757-80086 |
| ON/OFF overlay | 1 | 08757-80098 |
| Name plate (Agilent Technologies) | 1 | 08757-80099 |
| EPROM (U7) | 1 | 08757-80103 |
| EPROM (U29) | 1 | 08757-80104 |
| Hex nut (SMM3.0 6 SSHX) | 10 | 0535-0031 |
| Screw (SMM3.0 8 CWPNTX) | 15 | 0515-0372 |
| Screw (SMM3.0 10 CWPNTX) | 12 | 0515-0374 |
| Screw (SMM3.0 16 CWPNTX) | 4 | 0515-0375 |

Table 1 Upgrade Kit Contents (08757-60159)

| Description | Qty | Part Number |
|----------------------------------|-----|-------------|
| Screw (SMM4.0 10 CWPNTX) | 19 | 0515-0380 |
| Screw (SMM3.0 6 CWPNTX) | 10 | 0515-0430 |
| Screw (SMM3.5 6 PCFLTX) | 10 | 0515-1382 |
| Screw (SMM5.0 10 PCFLTX) | 4 | 0515-1384 |
| Screw (SMM3.0 20 CWPNTX) | 6 | 0515-1410 |
| Screw (SMM4.0 7 PCFLTX) | 12 | 0515-2086 |
| Screw (SMM3.5 8 PCPNTX) | 6 | 0515-1402 |
| Cable clamp (rear frame) | 1 | 1400-0017 |
| Tie wrap | 6 | 1400-0249 |
| Actuator clamp (CLP CA.15DI.62W) | 1 | 1400-0510 |
| Switch guide spring | 2 | 1460-1573 |
| RPG assembly | 1 | 1990-1525 |
| FUSE (F5) (5A 250V) | 1 | 2110-0010 |
| Washer | 4 | 2190-0016 |
| Hex-nut | 2 | 2950-0043 |
| Grommet (CHANNEL NPR.047W) | 1 | 4320-0002 |
| Label (5 amp fuse) | 1 | 9320-5885 |
| RPG knob | 1 | 01650-47401 |

Installation Procedure for the Upgrade Kit

The network analyzer must be in proper working condition prior to installing this option. Any necessary repairs must be made before proceeding with this installation.

WARNING **The servicing instructions are for use by qualified personnel only. To avoid electrical shock, do not perform any servicing unless you are qualified to do so.**

Electrostatic Discharge Protection

Protection against electrostatic discharge (ESD) is essential while removing or connecting cables or assemblies within the network analyzer.

Static electricity can build up on your body and can easily damage sensitive internal circuit elements when discharged. Static discharges too small to be felt can cause permanent damage. To prevent damage to the instrument:

- *always* wear a grounded wrist strap having a 1 M Ω resistor in series with it when handling components and assemblies.
- *always* use a grounded, conductive table mat while working on the instrument.
- *always* wear a heel strap when working in an area with a conductive floor. If you are uncertain about the conductivity of your floor, wear a heel strap.

Figure 1-1 shows a typical ESD protection setup using a grounded mat and wrist strap. Refer to Table 2, “Required Equipment and Tools” on page 8 for part numbers.

Figure 1-1 ESD Protection Setup

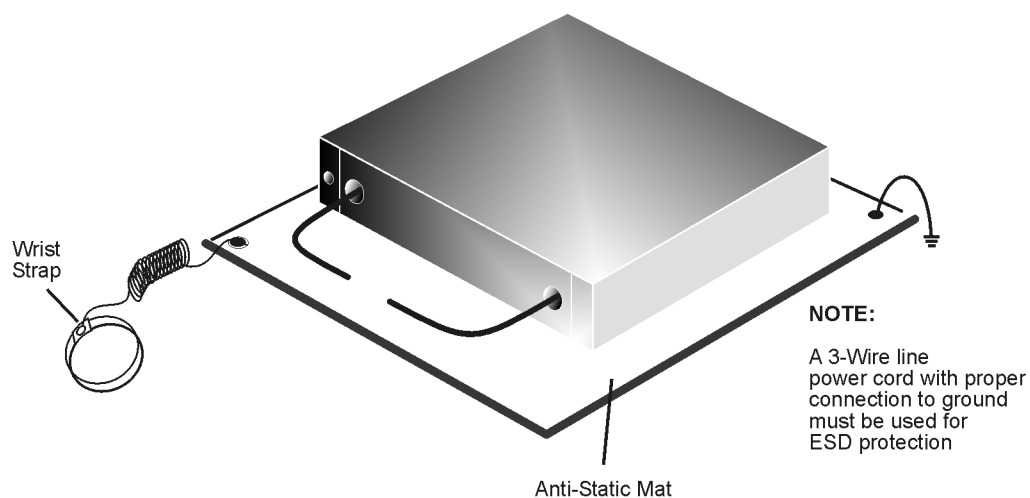

ku310b

Overview of the Installation Procedure

1. Remove the outside covers.
2. Remove the inside covers.
3. Remove the front panel.
4. Remove the CRT.
5. Remove the rear panel.
6. Remove the power supply board.
7. Remove the front frame.
8. Remove the CRT shield.
9. Install the LCD shield.
10. Install the front frame.
11. Install the power supply board.
12. Install the rear panel assembly.
13. Install the keypad board.
14. Install the keypad assembly.
15. Install the LCD assembly.
16. Install the display interface board.
17. Final button-up.
18. Operator's check.
19. Troubleshooting.

Equipment and Tools Required

Table 2 Required Equipment and Tools

| Description | Part Number |
|--|--------------------|
| T-10 TORX driver (set to 10 in-lbs) | N/A |
| T-15 TORX driver (set to 21 in-lbs) | N/A |
| 15/64 open-end wrench | N/A |
| Hex screwdriver (5.5 mm) | N/A |
| Flatblade screwdriver (small) | N/A |
| Needle-nose pliers | N/A |
| ESD grounding wrist strap | 9300-1367 |
| 5 ft grounding cord for wrist strap | 9300-0980 |
| 2 x 4 ft conductive table mat and 15 ft grounding wire | 9300-0797 |
| ESD heel strap (for use with conductive floors) | 9300-1308 |

Step 1. Remove the Outside Covers

WARNING

The opening of covers or removal of parts is likely to expose dangerous voltages. Disconnect the product from all voltage sources while it is being opened.

Refer to [Figure 1-2](#).

1. Disconnect the power cord.
2. Remove the strap handle by removing two screws (item ①).
3. Remove the four rear panel feet (item ②).
4. Loosen the top cover screw (item ③) and slide the top cover off.
5. Slide the side covers off. One side cover has a rear center screw.
6. Loosen the bottom cover screw (item ③) and slide the bottom cover off.
7. Remove the trim strip (item ④). Use a flatblade screwdriver to lift it out of the frame.

Figure 1-2 Outside Cover Removal

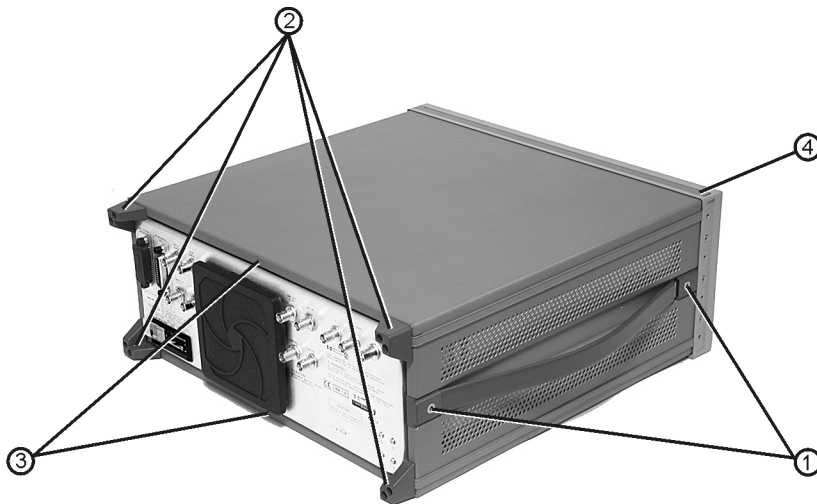

ja61d

Step 2. Remove the Inside Covers

Refer to [Figure 2-1](#).

1. Remove the logger cover by removing two screws (item ①).
2. Remove the CRT cover by removing twelve screws:
 - five screws (item ②) (Two of these screws do not hold the cover in place, but need to be removed.)
 - five screws (item ③)
 - two screws (item ④)

Figure 2-1 Inside Cover Removal

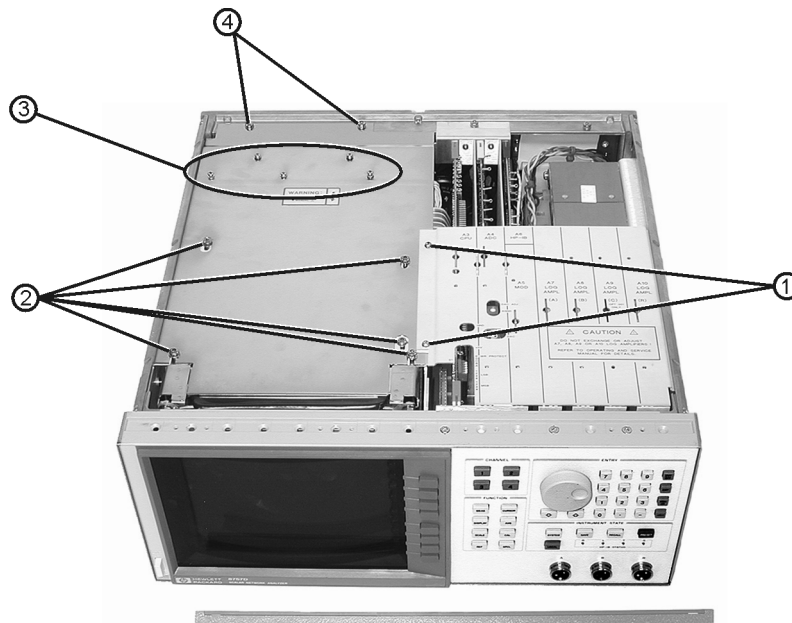

ja66d

Step 3. Remove the Front Panel

Refer to [Figure 3-1](#).

1. Turn the instrument over to expose the bottom side of the instrument.
2. Disconnect the detector connections (J2, J3, J4, and J5) from the motherboard. (There may be three or four depending on the option configuration.)

Figure 3-1 Detector Connectors

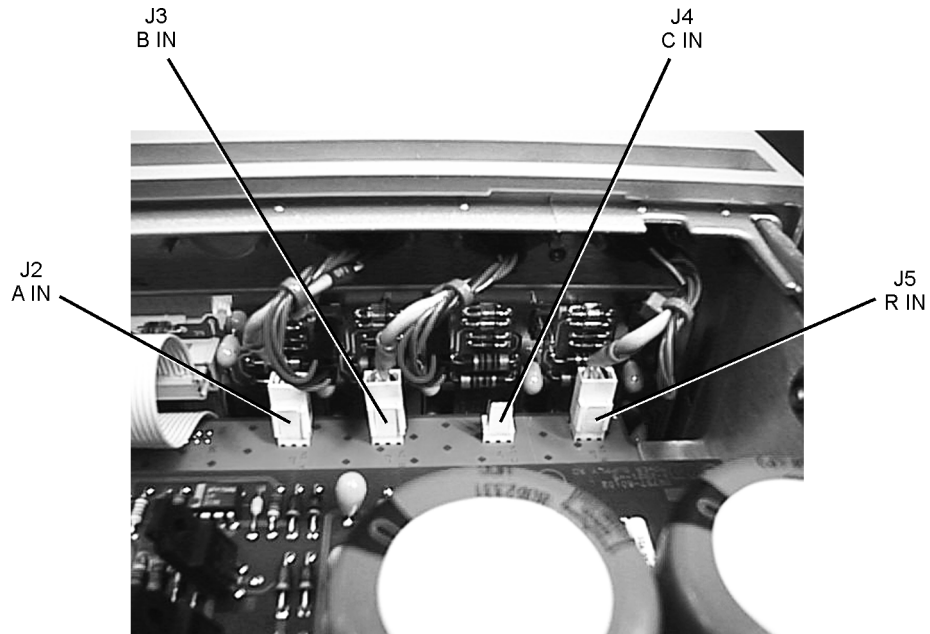

ja65d

Refer to [Figure 3-2](#).

3. Turn the instrument over to expose the top side of the instrument.
4. Remove the softkey cover (item ①). Gently lift the softkey cover off using something such as a flatblade screwdriver.
5. Remove the bezel by removing the two screws underneath the softkey cover.
6. Remove the two top and bottom frame screws (item ②).
7. Remove the two center screws (item ③) and tip the front panel partially out of the frame.

Figure 3-2 Front Panel Removal

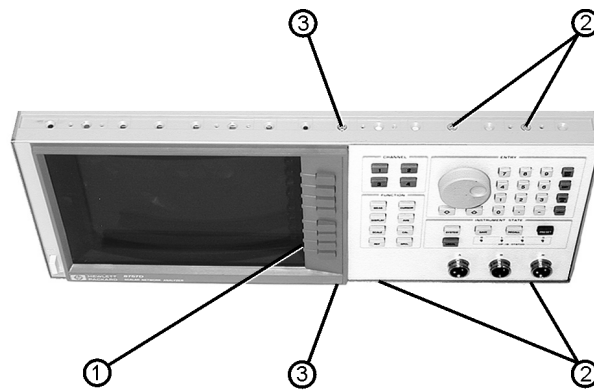

ja62d

NOTE

Option 002 has a gray RF cable that connects the keypad assembly to connector J1 on the CAL/MOD driver board (green guides). Lift the board slightly and use a 15/64 open-end wrench to disconnect the cable.

Refer to [Figure 3-3](#).

8. Disconnect the gray ribbon cable (item ④) from the motherboard. The front panel is now free from the analyzer.

Figure 3-3 Front Panel Ribbon Cable Removal

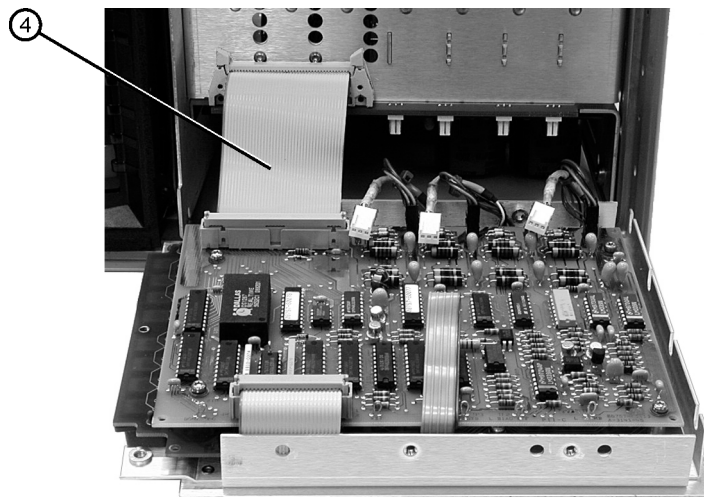

ja67d

Step 4. Remove the CRT

NOTE Recycle or dispose of the cathode ray tube (CRT) in accordance with applicable environmental laws.

Refer to [Figure 4-1](#).

1. Remove the connector clip from connector J4 and unplug the large ribbon cable (item ①).
2. Disconnect white power cable (item ②) from connector J1 on the graphics board and connector J1 on the power supply board. Discard the power cable. A new power cable with eight conductors is provided in the upgrade kit.
3. Disconnect the rear panel ribbon cable (item ③) from connector J2.

Figure 4-1 CRT Removal

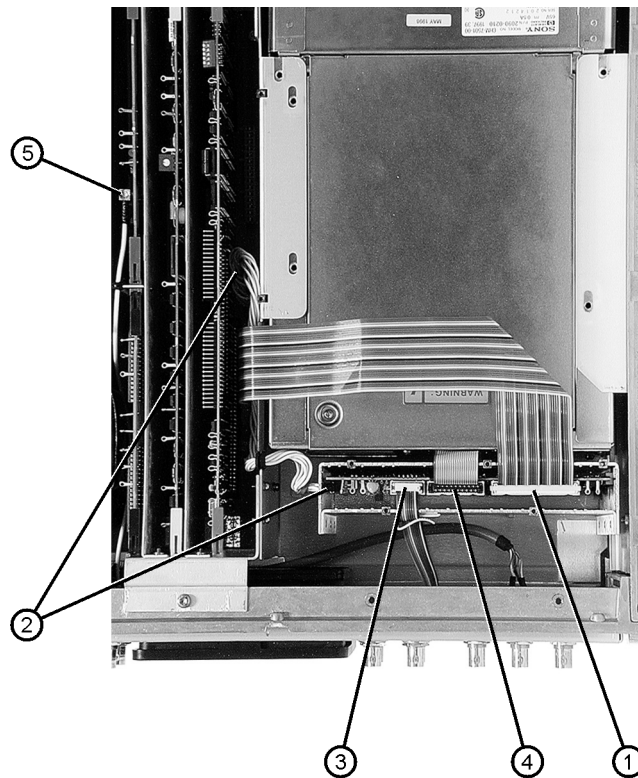

ja64d

4. Disconnect the gray CRT ribbon cable (item ④) from connector J3 by lifting the graphics board.
5. Remove the graphics board.
6. Slide the CRT out of the front frame.

7. Disconnect the white cable (item ⑤) from connector J2 by lifting the CAL/MOD driver board.

CAUTION

Mark the log amplifier boards (08757-60087) and the corresponding white board tab so that their placement order is uniquely identified. (Use a permanent marker). It will be necessary to replace each board in their original slot during the installation procedure. The instrument's calibration will be invalid if the boards are not replaced in their original positions.

8. Remove all of the printed circuit boards from the board cage:
 - CPU (orange guide)
 - ADC (yellow guide)
 - GPIB (blue guide)
 - CAL/MOD driver (green guide)
 - Log Amplifiers (white guide) (Refer to caution above.)

Step 5. Remove the Rear Panel

Refer to [Figure 5-1](#).

1. Turn the instrument over to expose the bottom side of the instrument.
2. Disconnect the thermistor switch by removing two screws (item ①).
3. Cut the two tie wraps that bundle the blue and red cables, and the gray and white/gray cables (item ②).
4. Disconnect the red and blue fan wires (item ③) from connector J3.
5. Using needle-nose pliers, disconnect the five transformer wires and one gray wire from the line module (item ④).
6. Using a flat blade screwdriver loosen, but do not remove, the nine screws on the green connectors and disconnect the eight transformer wires (item ⑤): red/blue/red, yellow/green/yellow, and purple/blank/purple.

Figure 5-1 Power Supply Cable Removal

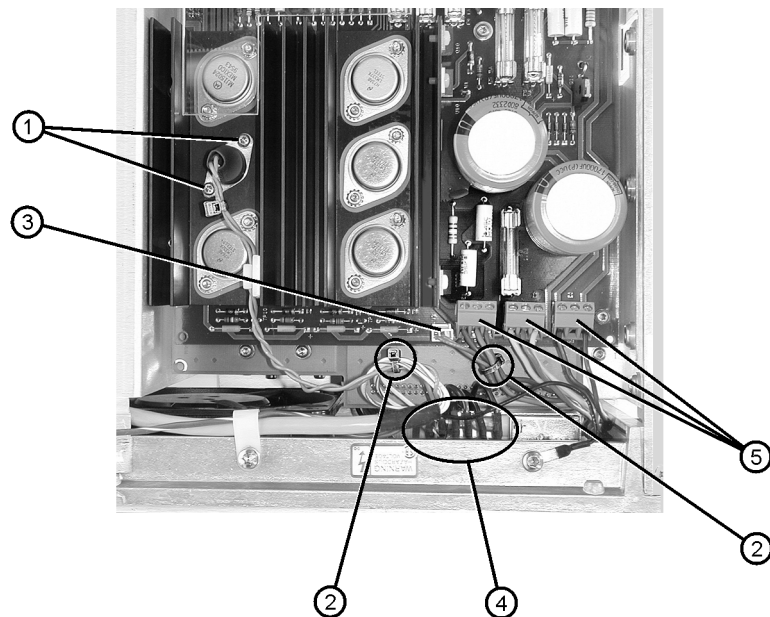

ja68d

Refer to [Figure 5-2](#).

7. Remove the four bottom and two top rear panel screws (item ⑥) and tip the rear panel partially out of the frame.
8. Disconnect the large gray ribbon cable (item ⑦) from the motherboard. The rear panel is now free from the analyzer. Discard the rear panel; a new one is provided in the upgrade kit.

Figure 5-2 Rear Panel Removal

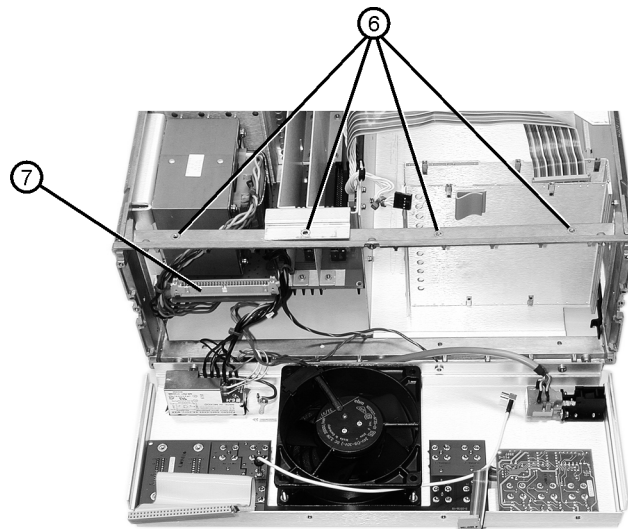

ja63d

Step 6. Remove the Power Supply Board

Refer to [Figure 6-1](#).

1. Remove the plastic warning shield on the power supply board. Using needle-nose pliers, pinch and hold the protruding plastic sleeve (item ①) while lifting the plastic shield off the board.

Figure 6-1 Plastic Warning Shield

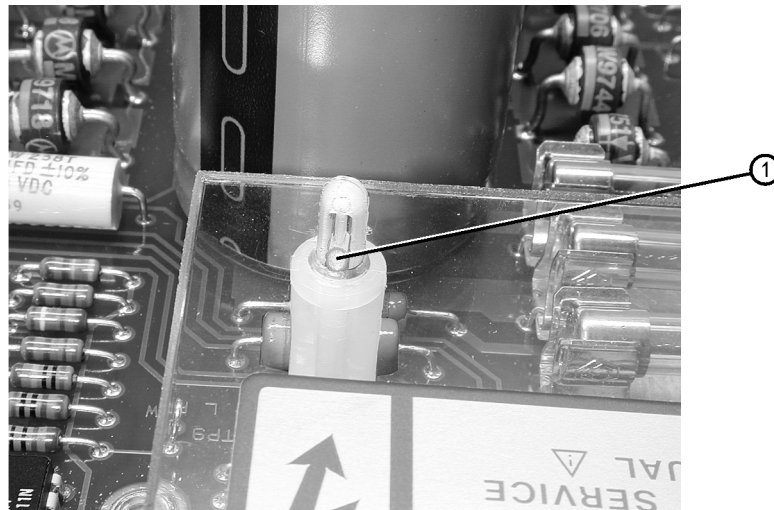

ja619d

Refer to [Figure 6-2](#).

2. Remove the power supply board by removing nine screws (item ②). Use the plastic ring (item ③) to help lift the board. You may encounter resistance as you are removing the board due to the length of the pins on connector J2.

Figure 6-2 Power Supply Board (top view)

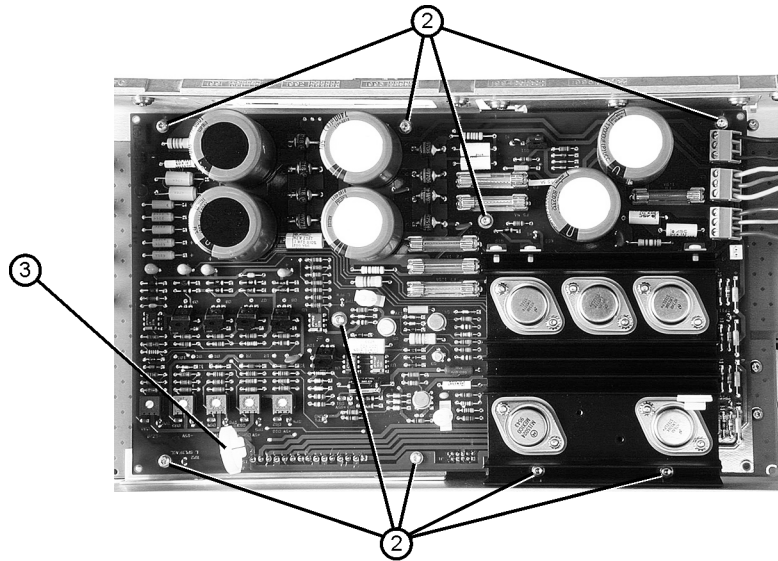

ja617d

Step 7. Remove the Front Frame

Refer to [Figure 7-1](#).

1. Remove the ON/OFF switch plate by removing three screws (item ①).
2. Remove the front frame by removing eight screws (item ②): four on each side of the instrument frame.

Figure 7-1 Front Frame

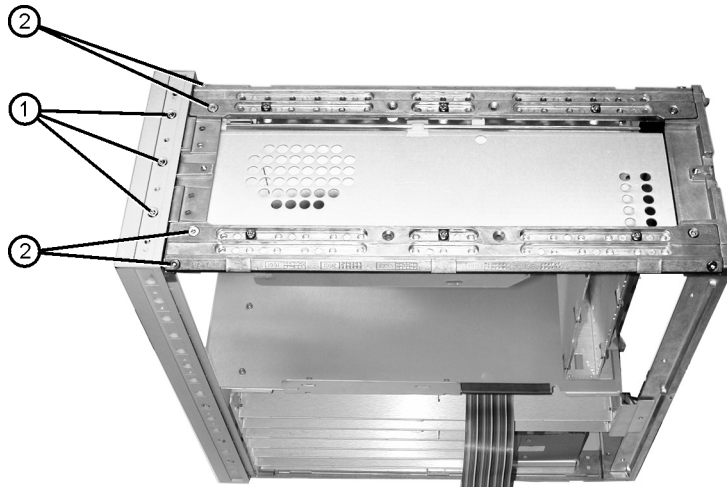

ja69d

Refer to [Figure 7-2](#).

3. Remove the ON/OFF switch guide along with the actuator rod by unhooking the spring (item ③) using needle-nose pliers. Once the switch guide is removed, pull the actuator rod off of the switch guide.

Figure 7-2 ON/OFF Switch



ja615d

Step 8. Remove the CRT Shield

Refer to [Figure 8-1](#).

1. Remove seven screws (item ①) on the bottom side of the CRT shield:
 - five attaching the graphics board shield to the CRT shield
 - two attaching the LCD shield to the motherboard

Figure 8-1 CRT Shield Removal (bottom)

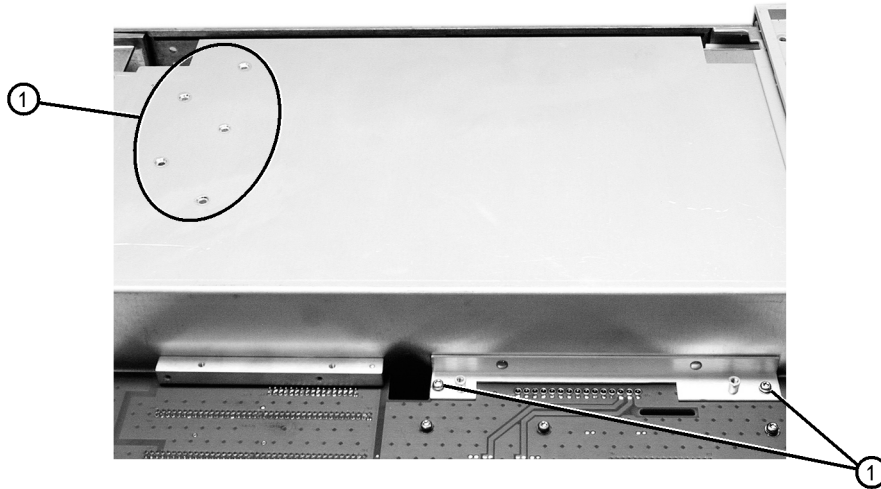

ja611d

Refer to [Figure 8-2](#).

2. Remove four screws (item ②) on the inside of the CRT shield.

Figure 8-2 CRT Shield Removal (inside)

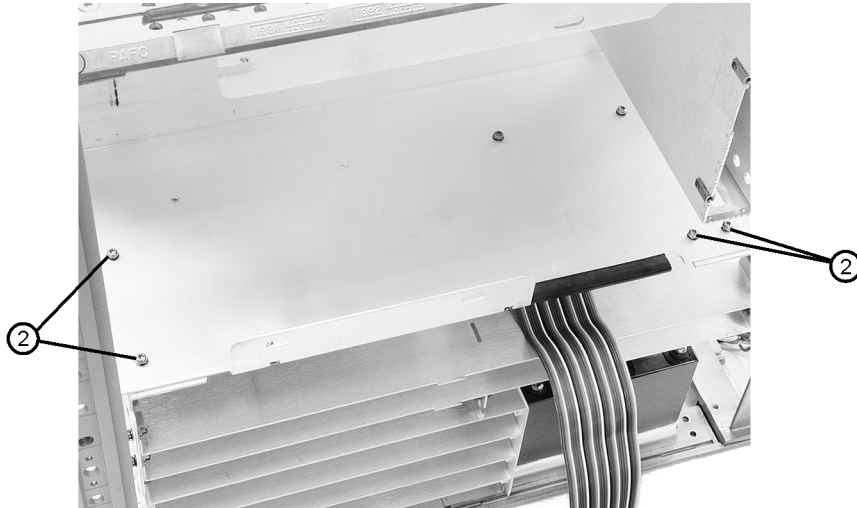

ja612d

Refer to [Figure 8-3](#).

3. Remove six screws (item ③) on the main frame and remove the CRT shield.

Figure 8-3 CRT Shield Removal (side)

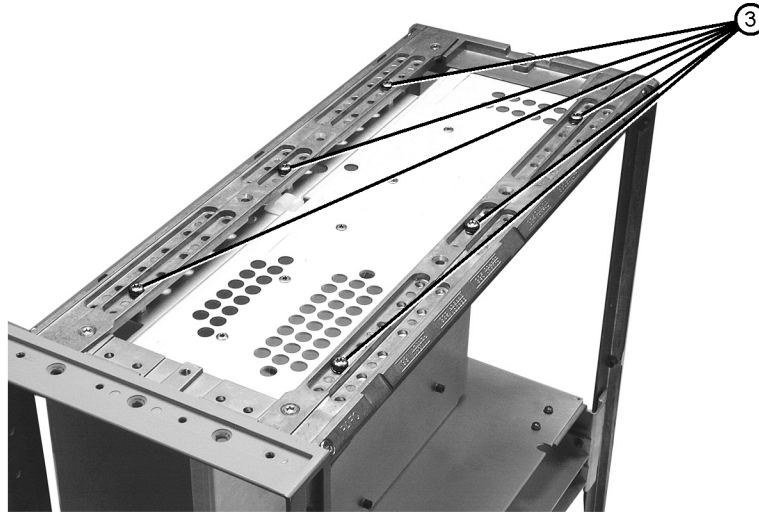

ja610d

The removal portion of this procedure is now complete.

Step 9. Install the LCD Shield

NOTE The new parts referenced in the installation procedure are listed in [Table 1, “Upgrade Kit Contents \(08757-60159\)”](#) on page 4.

Refer to [Figure 9-1](#).

1. Peel off the adhesive backing and attach the new actuator clamp (1400-0510) onto the new LCD shield (08757-00072). Align the clamp as shown in [Figure 9-1](#).

Figure 9-1 Actuator Clamp

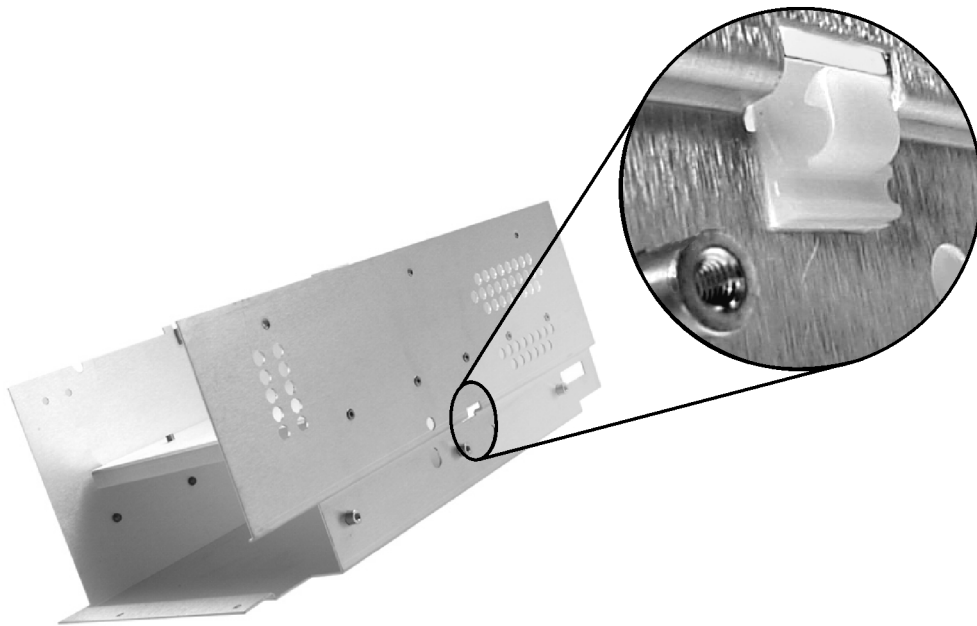

ja620d

Refer to [Figure 9-2](#).

2. Insert the new LCD shield into the mainframe. (The LCD shield fits on top of the rear frame, see [Figure 12-3 on page 36](#).)
3. Line up the holes and insert six screws (0515-0372):
 - four on the inside of the LCD shield (item ①)
 - two on the bottom side of the LCD shield (item ①)

Figure 9-2 LCD Shield Installation

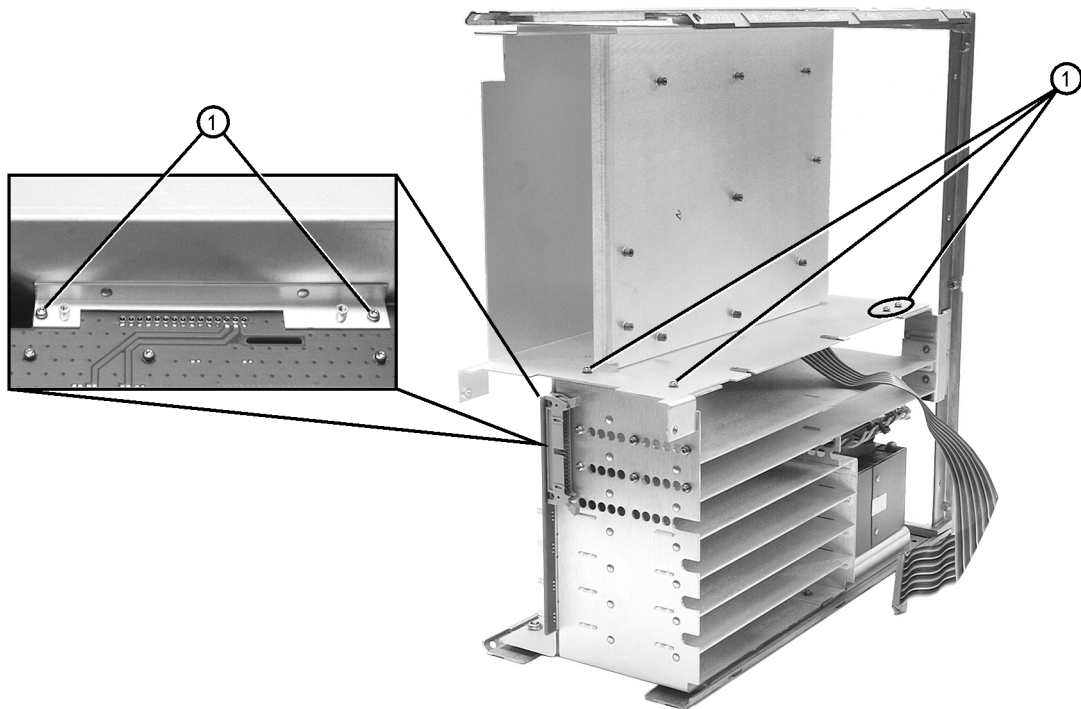

ja621d

Step 10. Install the Front Frame

NOTE Observe the top and bottom side of the front frame. The top side of the front frame has two different size holes. The bottom side holes are one size.

Refer to [Figure 10-1](#).

1. Insert the front frame into the main frame.
2. Insert ten screws (0515-2086) into the front frame (item ①):
 - four on each side of the instrument frame
 - one on the center top of the front frame
 - one on the center bottom of the front frame
3. Insert six screws (0515-0380) on the LCD shield side of the frame (item ②).

Figure 10-1 Insert Front Frame

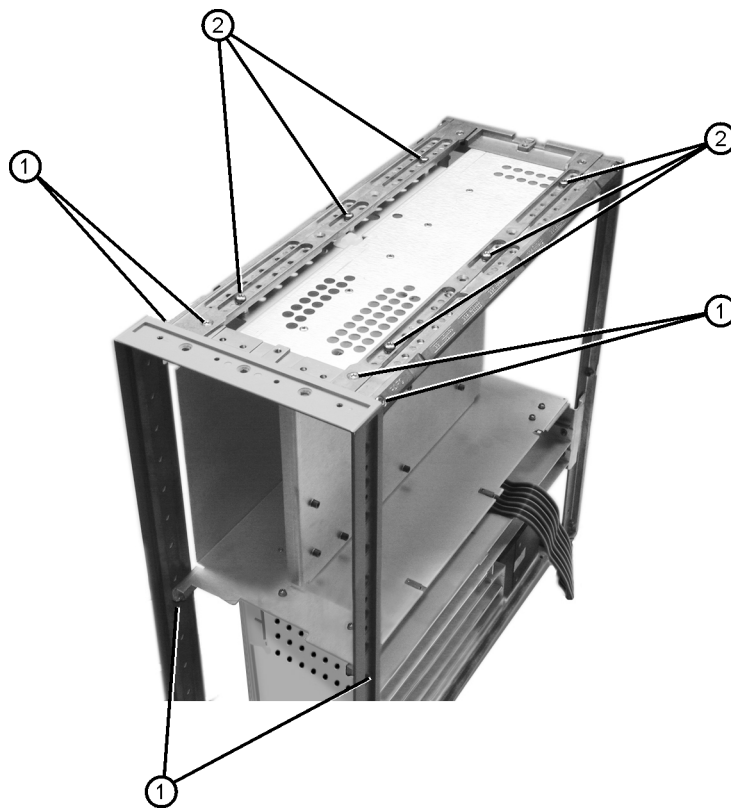

ja616d

Refer to [Figure 10-2](#).

4. Remove the plastic ON/OFF button (item ③) from the old switch guide and place it on the new switch guide (08757-40008).
5. Attach a new spring (1460-1573) to the new switch guide (item ④). Pinch the end of the spring closed using needle-nose pliers.

Figure 10-2 Actuator Guide

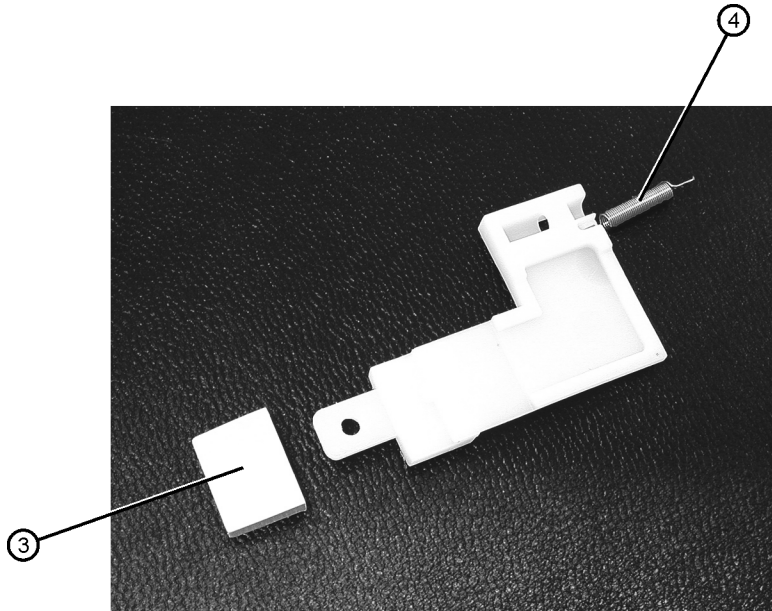

ja618d

Refer to [Figure 10-3](#).

6. Insert the actuator rod into the switch guide (item ⑤).
7. Insert the actuator rod into the actuator clamp (item ⑥) through the front of the instrument.

Figure 10-3 Actuator Rod

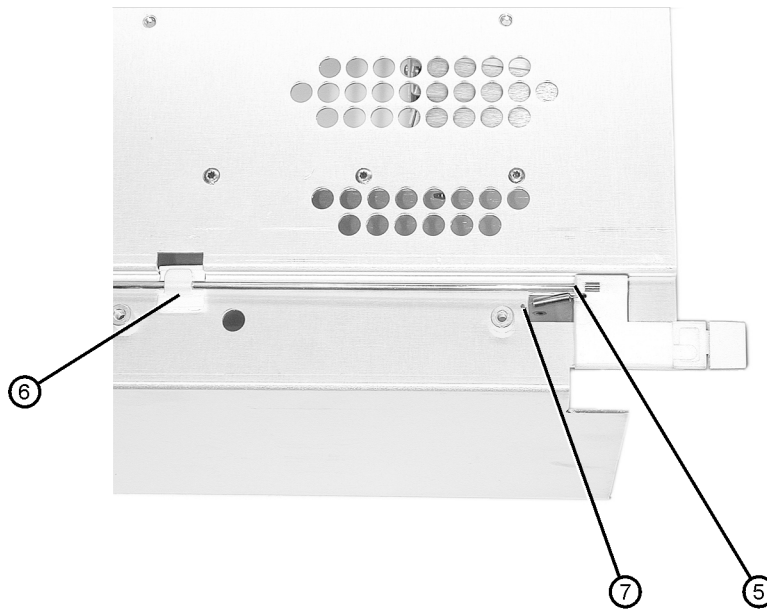

ja622d

8. Turn the instrument over and attach the spring to the LCD shield (item ⑦). Refer to [Figure 7-2 on page 21](#) for more detail.

Refer to [Figure 10-4](#).

9. Place the black actuator extender (item ⑧) on the opposite end of the actuator rod. Using needle-nose pliers, push back on the actuator rod and insert the extender.
10. Press the actuator extender several times to ensure that the switch moves freely. If necessary, use a flat blade screwdriver to widen the plastic actuator clamp. This will loosen the tension on the actuator rod.

Figure 10-4 Actuator Extender

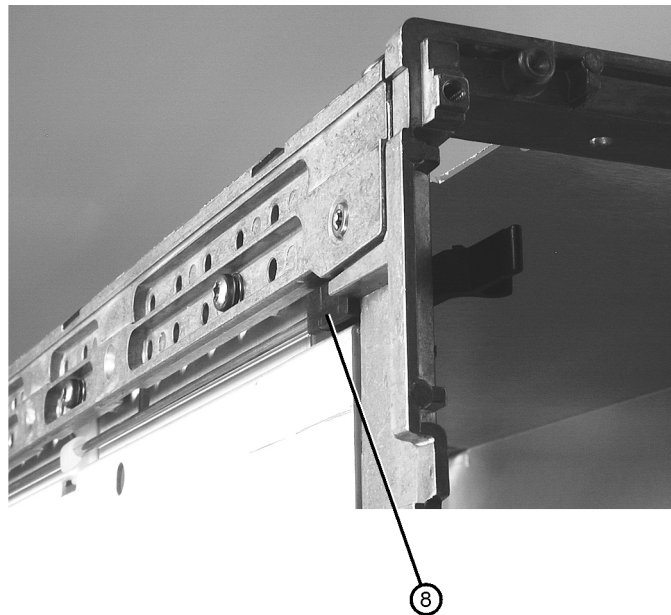

ja613d

Step 11. Install the Power Supply Board

Refer to [Figure 11-1](#).

1. Replace fuse F5 (item ①) on the power supply board with the 5-amp fuse (2110-0010) provided in the kit.
2. Place the identifying fuse label (9325-5885) over the 4-amp silk screening (item ②) on the board.

Figure 11-1 Fuse (5 Amp)

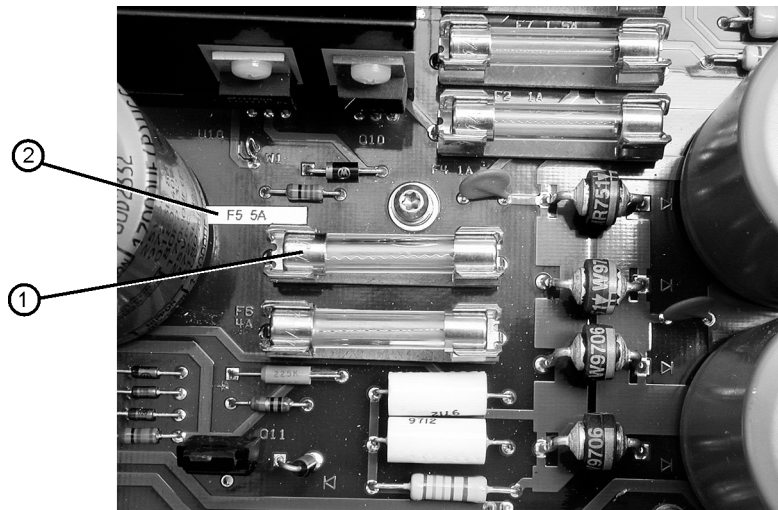

ja634d

Refer to [Figure 11-2](#).

3. Add a tie wrap (1400-0249) to secure the new white power cable (08757-60071), (item ③). The new power cable contains eight conductors.
4. Connect the new white power supply cable to connector J1 (item ④) on the back side of the power supply board.

Figure 11-2 Power Supply Board (bottom)

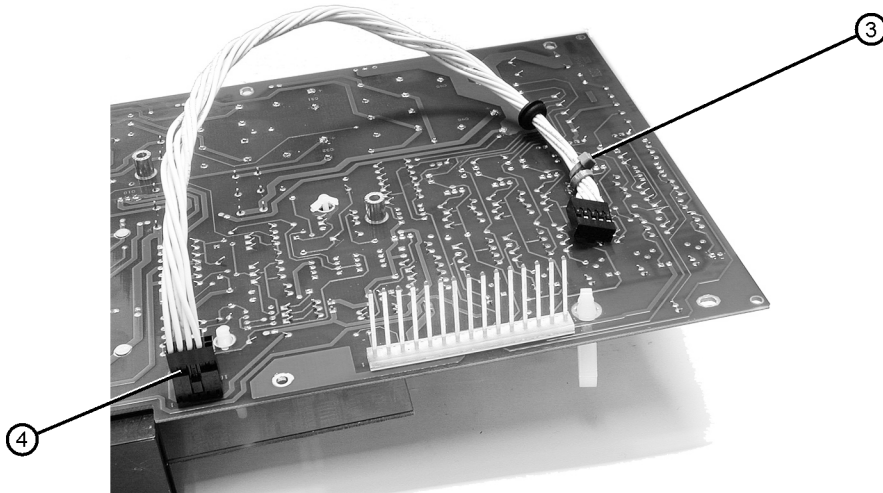

ja631d

CAUTION

As you are inserting the power supply board, carefully align the pins on connector J2 to the connector on the motherboard.

Refer to [Figure 11-3](#).

5. Guide the power cable through the notch opening on the motherboard and insert the power supply board into the instrument.
6. Insert two screws (0515-0375), (item ⑤).
7. Insert two screws (0515-0374), (item ⑥).
8. Insert five screws (0515-0372), (item ⑦).
9. Connect the transformer wires. See detail in [Figure 11-3](#) for orientation.
10. Tighten the connector screws using a flatblade screwdriver.
11. Attach the plastic shield to the power supply board. Refer to [Figure 6-1 on page 18](#).

Figure 11-3 Power Supply Board (top)

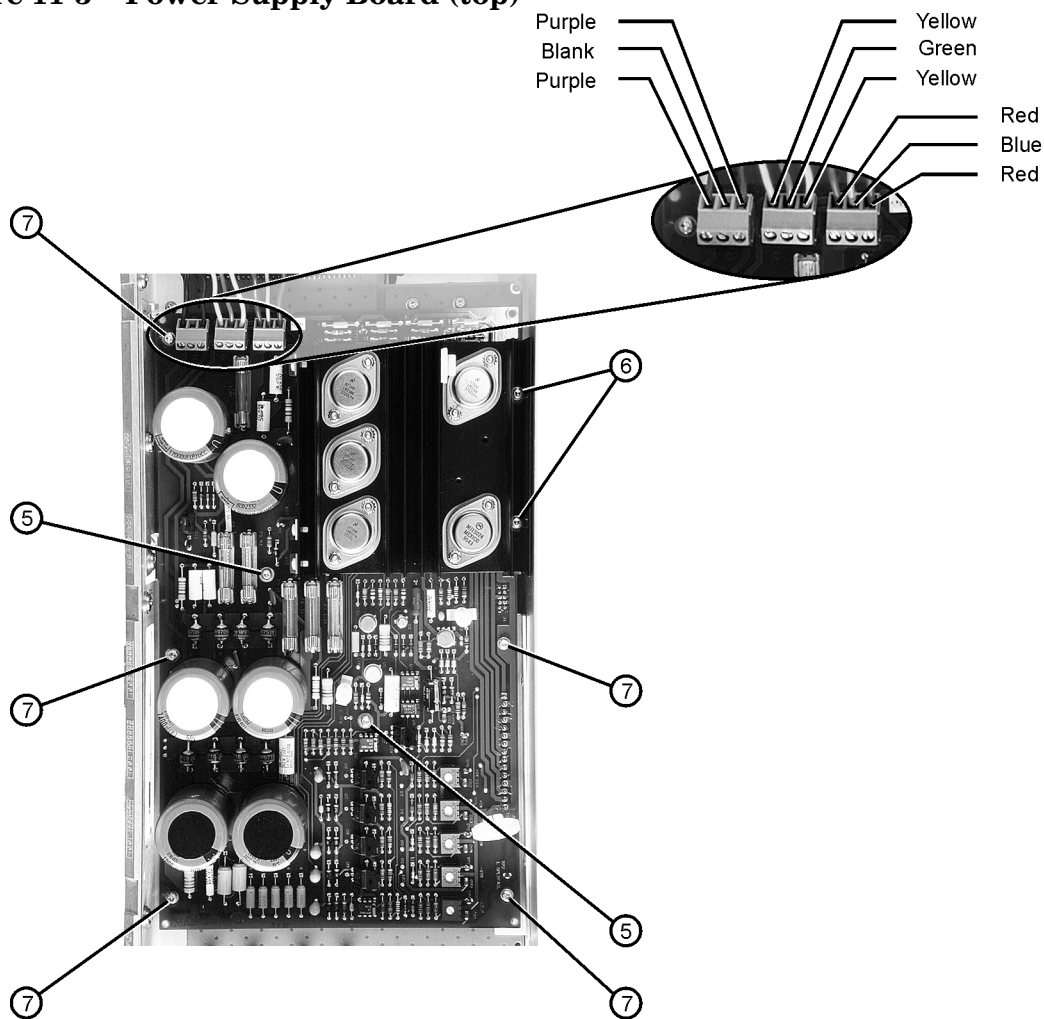

ja614d

Step 12. Install the Rear Panel Assembly

Refer to [Figure 12-1](#).

1. Place the white cable from the new rear panel assembly (08757-60153) through the rear frame (item ①) to the top side of the instrument. Route the cable past the transformer. It will be inserted into the CAL/MOD driver board, green guides, during the installation procedure.
2. Secure the two gray thermal cables together with a tie wrap (item ②).
3. Connect the large gray ribbon cable to connector J1 (item ③) on the motherboard.

Figure 12-1 Rear Panel Assembly

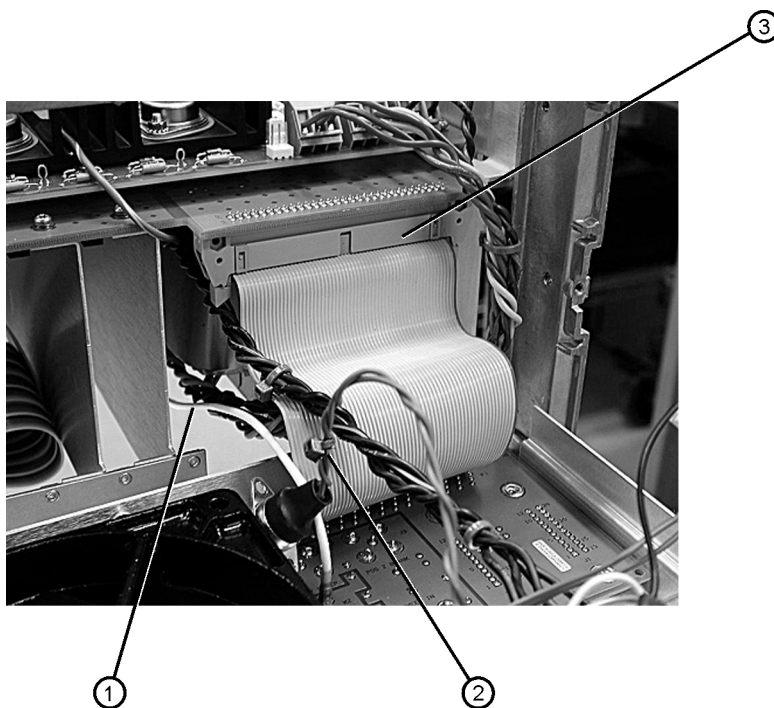

ja630d

Refer to [Figure 12-2](#).

4. Connect the transformer wires to the line module using needle-nose pliers.

Figure 12-2 Line Module Wires

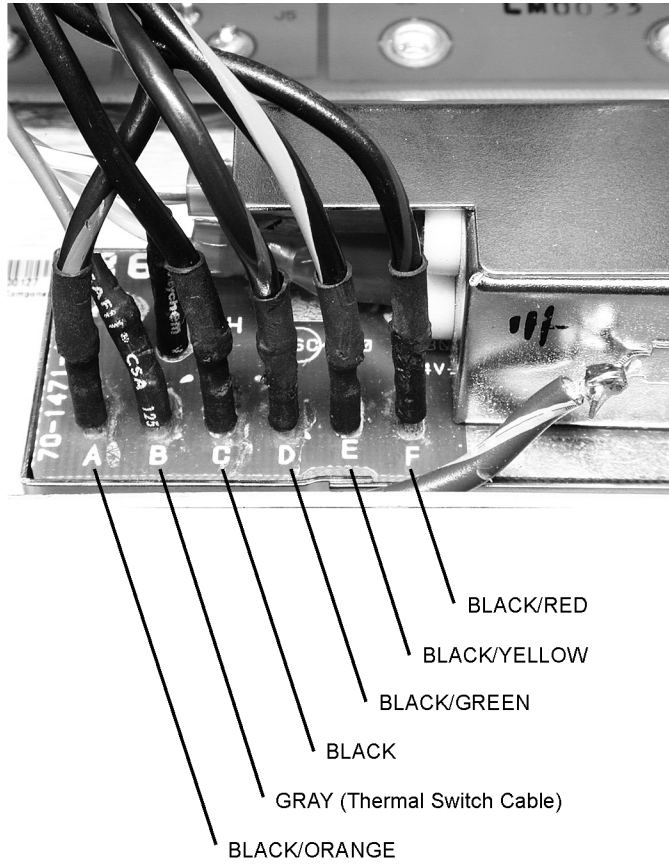

ja623d

Refer to [Figure 12-3](#).

5. Insert the new rear panel into the frame. Be sure all wires are clear of the fan and the frame.
6. Insert four screws (0515-0380), (item ④). Each will include one of the following:
 - screw only
 - green/white wire
 - cable clamp (1400-0017) secures the gray fan cable and the green/white wire. Orient the clamp so that the flat side is toward the bottom of the instrument.
 - black ground wire

Figure 12-3 Rear Panel Cables

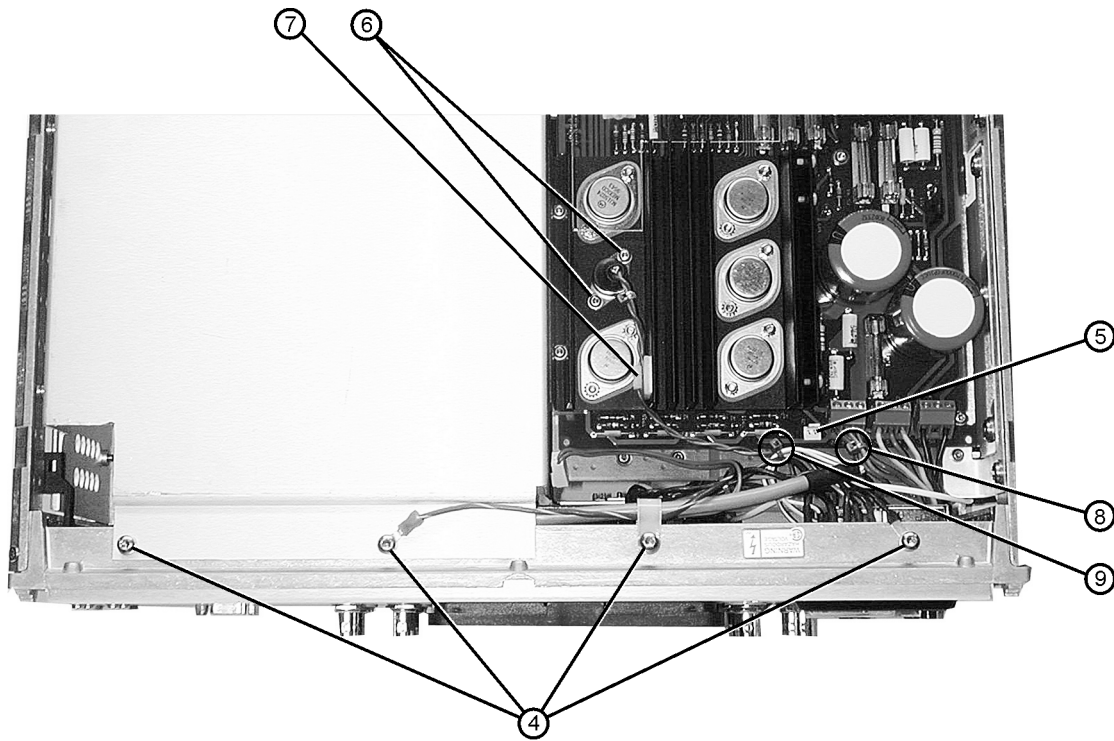

ja624d

7. Connect the fan wire (blue and red) to connector J3 (item ⑤).
8. Connect the thermal switch (item ⑥) using two screws (0515-0372).
9. Insert the thermal switch cable into the cable clamp (item ⑦) on the heat sink.
10. Secure the blue and red wires together (item ⑧) with a tie wrap (1400-0249).
11. Secure the white/grey wires and the gray thermal switch wire together with a tie wrap (1400-0249), (item ⑨).
12. Insert four screws (0515-0380) on the top side of the rear panel.

Step 13. Install the Keypad Board

Refer to [Figure 13-1](#).

1. Remove the detector interface connector cables (item ①) from the old front panel and place them on the new front sub-panel (08757-00071). Orient the notch, on the black portion of the connectors, down and secure the connectors using hex nut (0535-0031).
2. Select the front panel overlay required for your instrument configuration; four have been provided. Before you remove the adhesive backing, place the overlay into position and verify the alignment of the connectors. The edge of the overlay should extend evenly beyond the edges of the sub-panel. If necessary, loosen the connector nuts and adjust the connector positions slightly.
3. Peel off the adhesive backing, carefully align the corners, and attach the label to the new front sub-panel. Rub the label to make sure it adheres securely to the sheet metal.
4. Option 002 has an RF connector (item ②) on the front panel. Remove the RF connector from the old front panel and install it on the new front panel.

Figure 13-1 Keypad Board

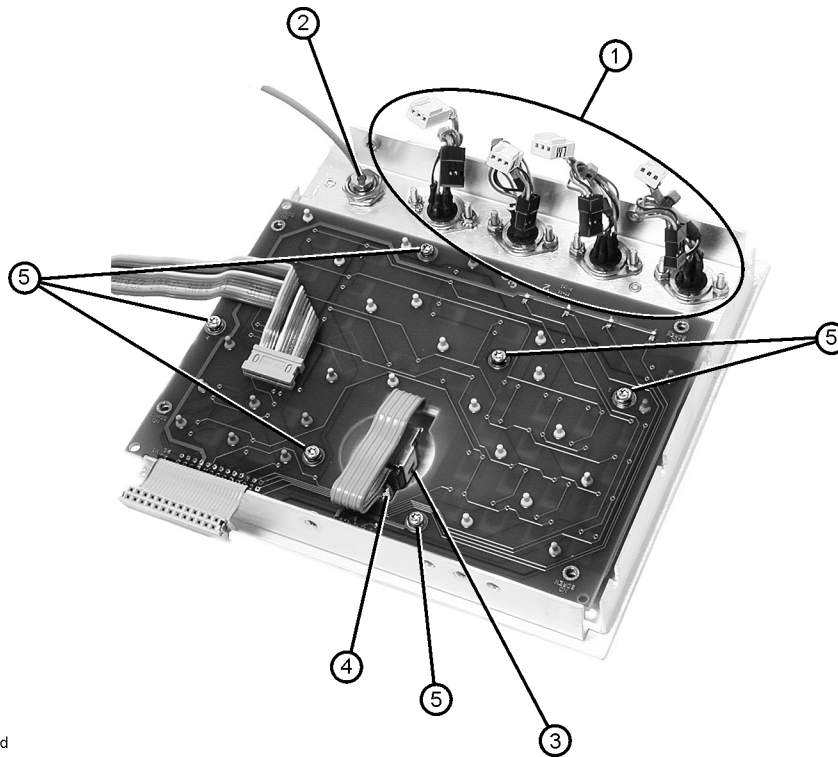

ja632d

5. Insert the new RPG assembly (1990-1525) with a washer (2190-0016) onto the new front panel (item ③). Orient the cable toward the top of the board. Add another washer and a nut (2950-0043).
6. Place the new main keypad rubber (08757-40017) onto the new keypad board (08757-60149).

Refer to [Figure 13-1 on page 37](#).

7. Connect the RPG cable to J1 (item ④) on the keypad board.
8. Pull the RPG cable through the hole on the keypad board and insert the board onto the sub-panel. Position the RPG cable as shown in [Figure 13-1 on page 37](#).
9. Insert 6 screws (0515-0374), (item ⑤) to secure the keypad board to the front sub-panel.
10. Push each button to ensure it moves freely when depressed. Adjust the position of the keypad board if necessary.

Refer to [Figure 13-2](#).

11. Insert the old display interface board (08757-60113) on top of the new keypad board.
12. Insert four screws (0515-1410), (item ⑥) to secure the display interface board to the keypad board.
13. Insert the ribbon cable from the keypad board into connector J2 (item ⑦) on the interface board.
14. Insert the black connectors on the detector cables (item ⑧) into connectors J3, J4, J5, and J6. (If there are only three detector cables, leave J5 empty.)
15. Push the new RPG knob (01650-47401) on to the front panel.

Figure 13-2 Display Interface Board

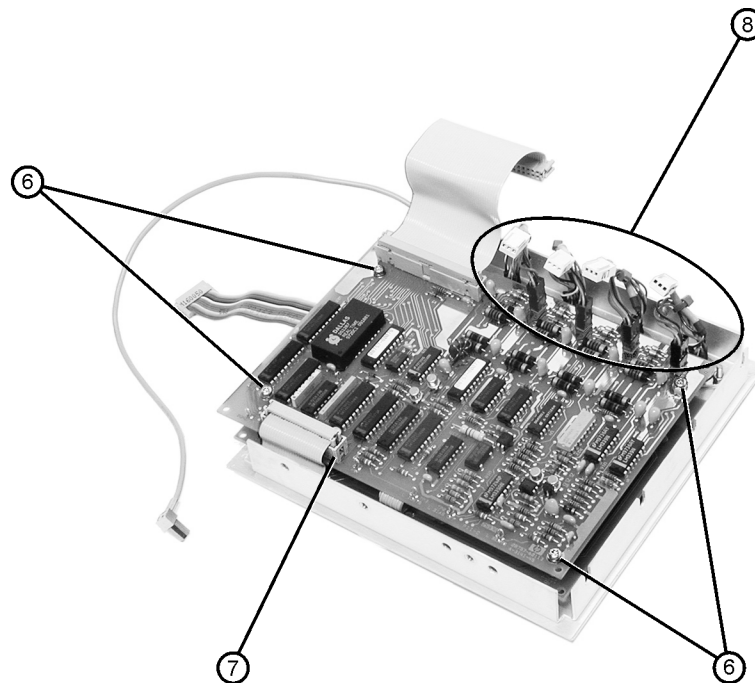

ja633d

Step 14. Install the Keypad Assembly

Refer to [Figure 14-1](#).

1. Connect the large gray ribbon cable to connector J1 (item ①) on the motherboard.
2. Connect the detector interface cables (item ②) to the motherboard. Refer to “[Detector Connectors](#)” on [page 11](#) for a more detailed image. (If there are only three detector cables, leave J4 empty.)
3. Option 002 has a gray RF connector on the front panel. Route this cable into the card cage slot with green guides. It will be inserted into the CAL/MOD driver board later in this procedure.
4. Insert the keypad assembly into the front frame.
5. Insert four screws (0515-1382). There are two screws on the top and two on the bottom of the keypad assembly. Refer to [Figure 3-2 on page 12](#).

Figure 14-1 Keypad Assembly

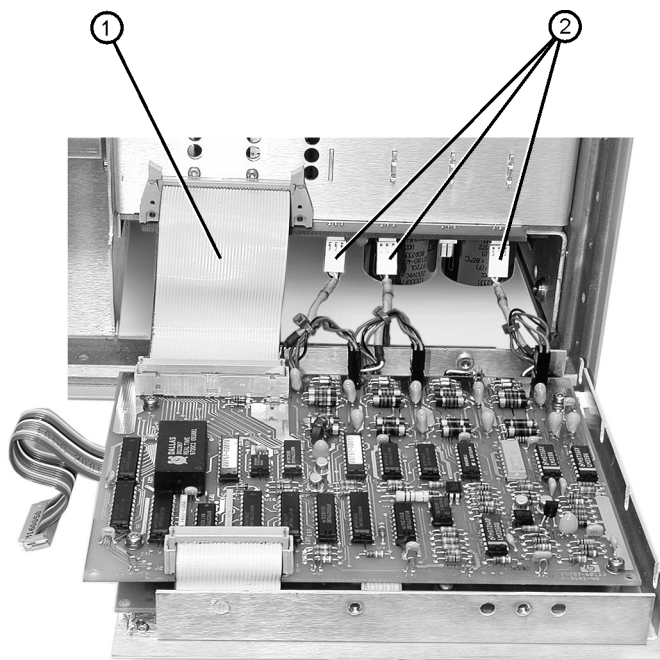

ja627d

Step 15. Install the LCD Assembly

Refer to [Figure 15-1](#).

1. Attach the new Agilent Technologies name plate (08757-80099) (item ①) on the front of the new LCD assembly (08757-60151).
2. Attach the ON/OFF overlay (08757-80098), (item ②).

Figure 15-1 Front Panel Label



ja635d

Refer to [Figure 15-2](#).

3. Connect the small ribbon cable (item ③) from the keypad assembly to the LCD assembly.

CAUTION It is imperative that the correct screws be used to secure the LCD assembly. Incorrect screw length may damage the LCD.

4. Place the new LCD assembly into the front frame and insert four screws (0515-1382), (item ④). There are two screws on the top and two on the bottom of the LCD assembly.
5. Press the ON/OFF switch several times to ensure that the switch moves freely. If necessary, adjust the actuator clamp to loosen the tension on the actuator rod.

Figure 15-2 LCD Assembly

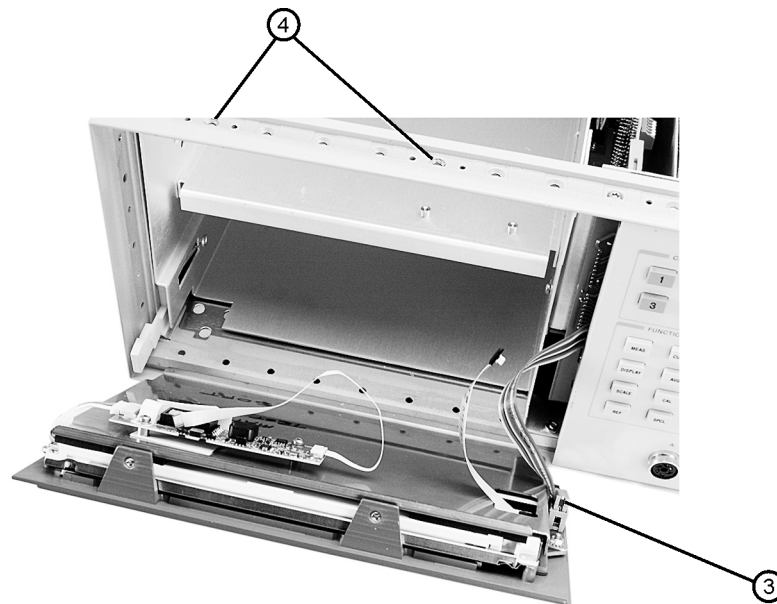

ja628d

Step 16. Install the Display Interface Board

Refer to [Figure 16-1 on page 43](#).

1. Place the new display interface board (85101-60293) into the LCD shield and insert eight screws (0515-0430), (item ①).
2. Connect the LCD data cable to connector J6 (item ②).
3. Open the locking device on connector J7 (item ③) by pulling the collar forward and inserting the flat flex cable with the metal conductive traces facing upward.
4. Close the locking device on J7.
5. Insert the new rubber grommet (4320-0002) on the LCD shield (item ④).
6. Connect the large ribbon cable from motherboard to connector J4 (item ⑤) and secure with the connector clip that was used on the old graphics board.
7. Connect the small ribbon cable from the rear panel to connector J2 (item ⑥). Fold the excess ribbon cable and place it into the clip on the rear panel.
8. Connect the new white power-cable to connector J3 (item ⑦). The new power cable has eight conductors.
9. Place the rubber grommet on the power supply cable into the notch on the LCD shield (item ⑧).

Figure 16-1 Display Interface Board

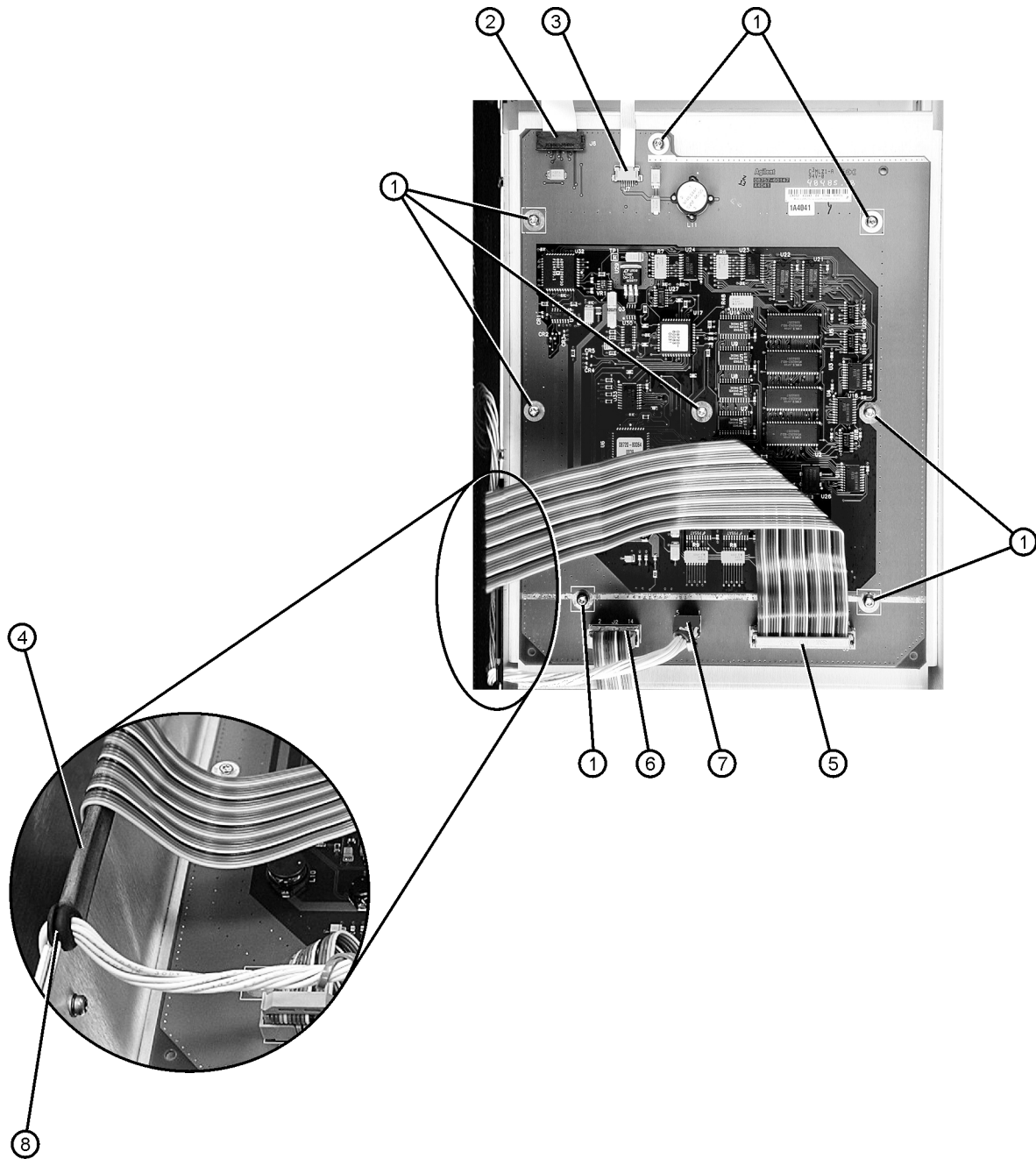

ja629d

Step 17. Final Button-Up

CAUTION Electrostatic discharge (ESD) can damage or destroy electronic components. All work on electronic assemblies should be preformed at a static-safe workstation. Refer to the documentation that pertains to your instrument for information about static-safe workstations and ordering static-safe accessories.

1. Using an IC extraction tool, gently remove EPROM U7 and U29 from their sockets on the CPU board (orange guides).
2. Insert the new EPROMs listed below. Place the notch on the EPROM toward the top of the board. Visually confirm that each pin is seated properly in the socket. The EPROMs listed below are for firmware revision 7.1 only.
 - U7 08757-80103
 - U29 08757-80104
3. Insert the previously removed printed circuit boards. Place the log amplifier boards (08757-60087 with white guides) in their correct positions.
4. Connect the white cable from the rear panel to connector J2 on the CAL/MOD driver board. Refer to [Figure 4-1 on page 14](#).
5. If Option 002, connect the gray RF cable from the keypad assembly to connector J1 on the CAL/MOD driver board.
6. Install the logger cover using two screws (0515-0374). Refer to [Figure 2-1 on page 10](#).
7. Install the outside covers. Refer to [Figure 1-2 on page 9](#).
8. Install the strap handle using two screws (0515-1384). Refer to [Figure 1-2 on page 9](#).
9. Install the rear feet using four screws (0515-1402).
10. Install the top trim strip.
11. Remove the serial number label from the old rear panel and place it on the new rear panel.

NOTE If the serial number label does not adhere properly, contact Agilent Technologies, [“Getting Assistance from Agilent” on page 2](#), for a replacement serial number label.

Step 18. Operator's Check

After upgrading your instrument, complete the following test to verify its performance.

1. Turn the power on.
2. Perform the Operator's Check. Refer to the Operating Reference 8757D Scalar Network Analyzer (08757-90169) on page A-1. The Operator's Reference is part of the Operating Manual (08757-90109).

Step 19. Troubleshooting

If there is a possibility that the log amplifier boards (white guides) were not replaced in their original positions, perform the following procedures.

1. Perform the Calibration Check Procedure. Refer to the Operating and Service Manual for the 11613B Calibrator (11613-90011). Follow the procedure given for the 8757A in Chapter 3.
2. If the Calibration Check Procedure fails, perform the Calibration Procedure. Refer to the Operating and Service Manual for the 11613B Calibrator (11613-90011). Follow the procedure given for the 8757A in Chapter 3.

